

STEVCO



SEALS

MECHANICAL SEAL SOLUTIONS



TYPE 2-3

(Similar to Crane type 2US)

DESIGN FEATURES & BENEFITS

Mechanical Drive

The drive band's notch design eliminates over-stressing of the elastomer bellows. This eliminates slippage, therefore protecting the sleeve and shaft from wear.

Self Aligning

Automatic adjustment compensates for abnormal shaft end play (run out), primary sealing wear, machinery tolerances and service life.

Non-Clogging, Single Coil Spring

Provides greater dependability than multiple spring designs. Will not run foul due to fluid contact.

Special Balancing

For higher pressure applications, greater operating speeds and lower wear.

Completely Field Repairable

The Type 2-3 seals can be repaired in the field to minimise replacement costs, downtime and lost revenue.

MATERIAL OPTIONS

Faces:

Rotary- Carbon, Tungsten Carbide and Silicon Carbide.

Stationary- Ceramic, Silicon Carbide, Tungsten Carbide and Ni-Resist.

Hardware:

304 S/S, 316 S/S and Monel.

SEAL APPLICATIONS

For confined space requirements and limited gland depths in pumps, mixers, agitators, blenders, compressors and other rotary shaft equipment.

For pulp and paper, wastewater treatment, petrochemical, food processing and other demanding applications.

Type 2-3 Seals are suitable for a wide range of service conditions from water to steam, to chemicals and corrosive materials.

OPERATING CONDITIONS

•Pressures:

Type 2-3: To 425psig (29.30 bar)
2930kPa

•Temperatures:

-40°C to +204°C

(See reverse page for Elastomer Graph)

STEVCO 2-3 SPECIFICATIONS

GA Drawing

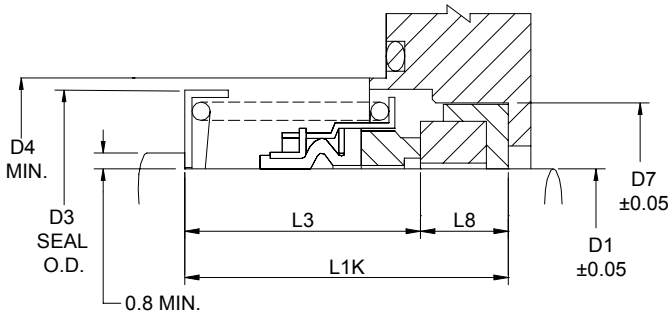

ELASTOMER TEMPERATURE LIMITS

BUNA (-40°C TO 107°C)

VITON (-29°C TO 204°C)

EPDM (-45°C TO 149°C)

NEOPRENE (-40°C TO 100°C)

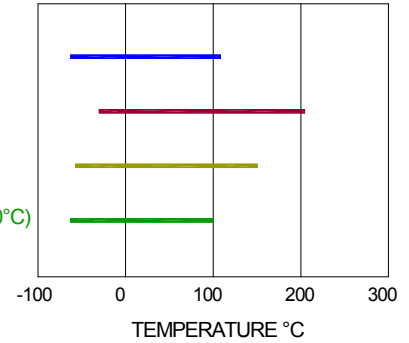

SEAL SIZE		D1	D3	D4	D7	L1K	L3	L8
Imperial	Metric							
0.375	9.52	9.52	26.19	30.95	22.22	28.54	20.62	7.92
0.500	12.70	12.70	30.15	34.92	25.40	28.54	20.62	7.92
0.625	15.87	15.87	34.92	39.67	31.75	32.53	22.22	10.31
0.750	19.05	19.05	38.10	42.85	34.92	32.53	22.22	10.31
0.875	22.22	22.22	41.27	46.02	38.10	34.11	23.80	10.31
1.000	25.40	25.40	46.02	50.80	41.27	36.50	25.40	11.10
1.125	28.57	28.57	49.20	53.98	44.45	38.07	26.97	11.10
1.250	31.75	31.75	52.37	57.15	47.62	38.07	26.97	11.10
1.375	34.92	34.92	57.15	61.90	50.80	39.67	28.57	11.10
1.500	38.10	38.10	60.32	65.07	53.97	39.67	28.57	11.10
1.625	41.27	41.27	69.04	74.60	60.32	47.62	34.92	12.70
1.750	44.45	44.45	69.85	77.77	63.50	47.62	34.92	12.70
1.875	47.62	47.62	73.02	80.95	66.67	50.80	38.10	12.70
2.000	50.80	50.80	76.20	84.12	69.85	50.80	38.10	12.70
2.125	53.97	53.97	82.55	92.07	76.20	57.12	42.85	14.27
2.250	57.15	57.15	85.72	95.25	79.37	57.12	42.85	14.27
2.375	60.32	60.32	88.90	98.42	82.55	60.29	46.02	14.27
2.500	63.50	63.50	92.07	101.60	85.72	60.29	46.02	14.27
2.625	66.67	66.67	98.42	109.52	85.72	65.07	49.20	15.87
2.750	69.85	69.85	101.60	112.70	88.90	65.07	49.20	15.87
2.875	73.02	73.02	104.77	115.87	95.25	68.24	52.37	15.87
3.000	76.20	76.20	107.95	119.05	98.42	68.24	52.37	15.87
3.125	79.37	79.37	115.87	127.00	101.60	75.39	55.55	19.84
3.250	82.55	82.55	119.05	130.17	104.77	75.39	55.55	19.84
3.375	85.72	85.72	122.22	133.35	107.95	75.39	55.55	19.84
3.500	88.90	88.90	125.40	139.70	111.12	75.39	55.55	19.84
3.625	92.07	92.07	130.17	144.45	114.30	78.56	58.72	19.84
3.750	95.25	95.25	133.35	147.62	117.47	78.56	58.72	19.84
3.875	98.42	98.42	138.10	152.40	120.65	81.74	61.90	19.84
4.000	101.60	101.60	141.27	155.57	123.82	81.74	61.90	19.84

PV LIMITS

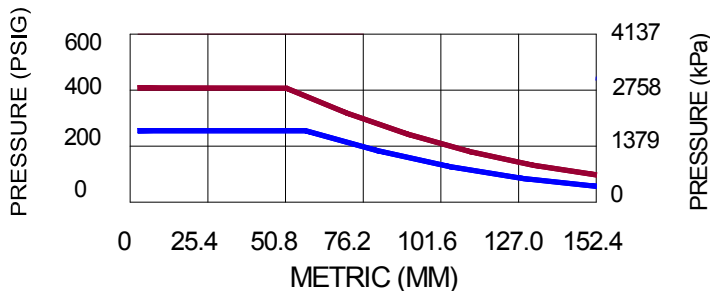

TYPE 2-3 CARBON VS TUNGSTEN CARBIDE (1800 RPM)

TYPE 2-3 CARBON VS CERAMIC (1800 RPM)

1. Lubricating liquid is defined as having lubricating properties of gasoline or better.



STEVCO SEALS AND PUMPS P/L

11 Samantha Place, SMEATON GRANGE NSW 2567 Ph (02) 4629 6500

STEVCO SEALS & PUMPS VICTORIA P/L

U8, 53 Gateway Blvd, EPPING VICTORIA 3076 Ph (03) 9408 3875