

STEVCO



SEALS

MECHANICAL SEAL SOLUTIONS



TYPE 5-0

(Similar to type T32)

DESIGN FEATURES & BENEFITS

OP Seat (Standard)

OP with circlip design prevents axial movement of mating ring. The stationary seat is only available in tungsten carbide and silicon carbide.

Enclosed Face Design

Shrouded disc allows seal to withstand constant movement and vibrations of mixer applications.

Debris Well Option

Isolates and captures face wear particles in gland cavity, preventing contamination of process liquid or gas. Pipe taps allow flushing during cleaning cycle.

Eliminates Double Seal Usage

Seal design eliminates the need for double seals with ancillary equipment in mixer applications.

Completely Field Repairable

The Type 5-0 seal can be repaired in the field to minimise replacement costs, downtime and lost revenue.

MATERIAL OPTIONS

Faces:

Rotary Face- Carbon (Grade A)
Stationary Seat- Tungsten Carbide
or Silicon Carbide

Hardware:

316 Stainless Steel

Springs:

Hast C

SEAL APPLICATIONS

For top entry mixers, agitators and reactor vessels.

Type 5-0 seals are an inside and outside mounted balanced seal, with the seal faces in contact during operation. No auxiliary equipment is required for lubrication.

These seals are excellent for operation in vacuum conditions, and meet the needs of pharmaceutical and chemical processing industries.

OPERATING CONDITIONS

•Pressures:

Type 5-0: Full vacuum to 213psig
(15 bar, 1500kPa)

•Temperatures:

-45°C to +204°C

(See reverse page for Elastomer Graph)

•Speed

To 18 mtrs/sec.

STEVCO 5-0 SPECIFICATIONS

GA Drawing

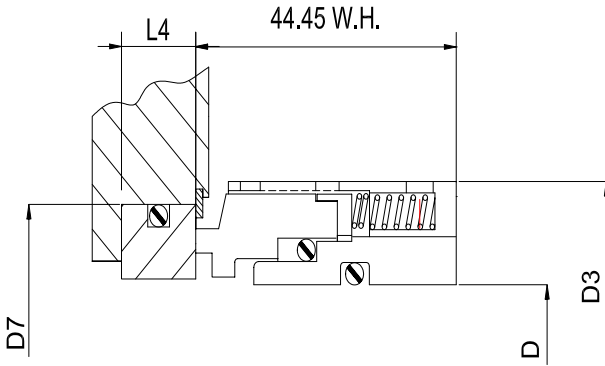

ELASTOMER TEMPERATURE LIMITS

EPDM -45°C TO 149°C

VITON -29°C TO 204°C

BUNA -40°C TO 107°C

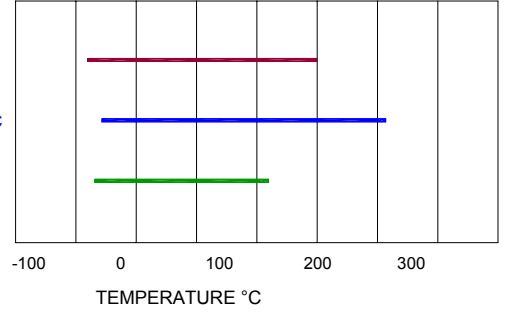

| SEAL SIZE | | D | D7 | D3 | L4 |
|-----------|--------|--------|--------|--------|-------|
| Imperial | Metric | | | | |
| 1.000 | 25.4 | 25.4 | 44.45 | 50.20 | 11.10 |
| 1.125 | 28.5 | 28.5 | 47.62 | 57.15 | 11.10 |
| 1.250 | 31.7 | 31.7 | 50.80 | 59.00 | 11.10 |
| 1.375 | 34.9 | 34.9 | 53.97 | 63.50 | 11.10 |
| 1.500 | 38.1 | 38.1 | 60.32 | 66.67 | 12.70 |
| 1.625 | 41.2 | 41.2 | 63.50 | 71.42 | 12.70 |
| 1.750 | 44.4 | 44.4 | 66.67 | 72.21 | 12.70 |
| 1.875 | 47.6 | 47.6 | 69.85 | 76.20 | 12.70 |
| 2.000 | 50.8 | 50.8 | 76.20 | 79.37 | 14.27 |
| 2.125 | 53.9 | 53.9 | 79.37 | 82.55 | 14.27 |
| 2.250 | 57.1 | 57.1 | 82.55 | 85.72 | 14.27 |
| 2.375 | 60.3 | 60.3 | 85.72 | 88.90 | 14.27 |
| 2.500 | 63.5 | 63.5 | 85.72 | 92.07 | 15.87 |
| 2.625 | 66.6 | 66.6 | 88.90 | 95.25 | 15.87 |
| 2.750 | 69.8 | 69.8 | 95.25 | 98.42 | 15.87 |
| 2.875 | 73.0 | 73.0 | 98.42 | 101.60 | 15.87 |
| 3.000 | 76.2 | 76.2 | 101.60 | 104.77 | 19.84 |
| 3.125 | 79.3 | 79.3 | 104.77 | 107.95 | 19.84 |
| 3.250 | 82.5 | 82.5 | 107.95 | 111.12 | 19.84 |
| 3.375 | 85.7 | 85.7 | 111.12 | 114.30 | 19.84 |
| 3.500 | 88.9 | 88.9 | 114.30 | 117.47 | 19.84 |
| 3.625 | 92.0 | 92.0 | 117.47 | 127.00 | 19.84 |
| 3.750 | 95.2 | 95.2 | 120.65 | 130.17 | 19.84 |
| 3.875 | 98.4 | 98.4 | 123.82 | 133.35 | 19.84 |
| 4.000 | 101.6 | 101.60 | 130.17 | 136.52 | 19.84 |



STEVCO SEALS AND PUMPS PTY LTD

11 Samantha Place, SMEATON GRANGE NSW 2567 ~ Ph (02) 4629 6500

STEVCO SEALS & PUMPS VICTORIA P/L

U8, 53 Gateway Blvd, EPPING VICTORIA 3076 Ph (03) 9408 3875