

R3

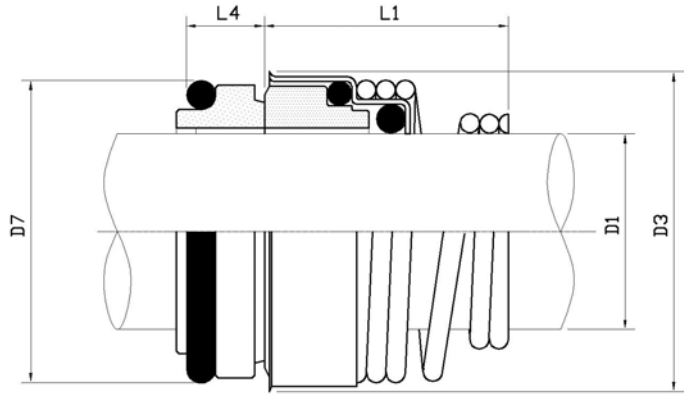

Design Features

Metric size shafts, seat comply with FE housing
 Conical spring dependent on direction of rotation
 Unbalanced seals
 HR3 is ceramic rotary and carbon seat as standed
 HR2 is stainless rotary and carbon seat as standed

Operating Conditions

Temperature: -30°C to +200°C
 (Depending on materials used)
Pressure: Up to 10 bar , 145 psi
Speed: Up to 10m/s, 2000fpm

Materials available

Seal face: ceramic, carbon, sic
Elastomer: nitrile, viton, EPD

Equivalent to

SIMPLEX, ROTEN3, ROTEN2

D1	D3	D7	L1	L4	L=L1+L4
10mm	20	18.1	15	5.5	20.5
12mm	22	20.6	18	5.5	23.5
14mm	25	23.1	22	6.0	28.0
15mm	29	26.9	22	7.0	29.0
16mm	29	26.9	23	7.0	30.0
17mm	29	26.9	23	7.0	30.0
18mm	33	30.9	24	8.0	32.0
19mm	33	30.9	25	8.0	33.0
20mm	33	30.9	25	8.0	33.0
21mm	38	35.4	25	8.0	33.0
22mm	38	35.4	25	8.0	33.0
23mm	38	35.4	27	8.0	35.0
24mm	38	35.4	27	8.0	35.0
25mm	40	38.2	27	8.5	35.5
28mm	46	43.3	29	9.0	38.0
29mm	46	43.3	30	9.0	39.0
30mm	46	43.3	30	9.0	39.0
32mm	46	43.3	30	9.0	39.0
33mm	48	53.5	39	11.5	50.5
35mm	50	53.5	39	11.5	50.5
38mm	56	60.5	39	11.5	50.5
40mm	58	60.5	39	11.5	50.5

R2

